

DESIGN AND LICENSING OF THE UKAEA IP 2m BOX

R P Hows, S Marshall and R A Vaughan

Croft Associates Ltd, F4 Culham Science Centre
Abingdon, Oxfordshire, United kingdom, OX14 3DB

Tel 01865 407740 Email sales@croftltd.com

ABSTRACT

Croft was contracted by UKAEA, Winfrith in 2006 to design, manufacture, test and license an ILW IP transport packaging (UKAEA 2m Box Design No 3954) for decommissioning waste from the Dragon and SGHWR reactors at Winfrith. The package had to meet the requirements of the existing NDA (Nirex) 2m Box specification. The UKAEA 2m Box is intended for on-site storage at Winfrith and possibly another site for 50 years and subsequent transport to the NDA repository without further processing. The design of the box closure includes a leak testable sealing system which is capable of being replaced at a later date (eg before shipment), by the removal of the lid and replacement of seals remote from the box location.

Initially the specification for the UKAEA 2m Box called for rating for gross weight of 40t, but this was raised to 50t as it was realised that the efficient use of the capacity of the box would result in a 50t gross weight.

Two prototype 2m Boxes were produced with one being provided with 100mm of concrete shielding and the other without any shielding. This shielded box was filled with simulated waste and a concrete grout cap fitted and the 50t package was dropped onto the massive target at Winfrith from a height of 300mm (this being the regulatory test height). The test showed that the box performed as expected; meeting all requirements. In particular: there was no loss of shielding and no effect on the containment system that would reduce its effectiveness.

INTRODUCTION

The UKAEA, Winfrith in 2006 were under contract with the NDA to prepare for decommissioning waste from the Dragon and SGHWR reactors at Winfrith. One requirement was to design, manufacture, test and license an ILW IP transport packaging (called the UKAEA 2m Box Design No 3954) for on-site storage at Winfrith and possibly another site for 50 years and subsequent transport to the NDA repository without further processing. The package had to meet the requirements of the existing NDA (Nirex) 2m Box specification. The UKAEA, Winfrith contracted Croft to design, manufacture, test and license the required ILW IP transport packaging.

The UKAEA 2m Box is designed as an Industrial Package Type 2 (IP-2) in accordance with the IAEA Transport Regulations [ref 1] and is intended for LLW and

ILW that meets the requirements for Low Specific Activity (LSA) material and/or Surface Contaminated Objects (SCO).

The capacity of the UKAEA 2m Box has been maximized by rating it for gross weight of 50t. The box is designed for 0 to 300 mm concrete shielding cast on the sides and base before loading and for a concrete cap of the same thickness. The design also assumes that the contents will be grouted before transport

The design of the box closure includes a leak testable sealing system which is capable of being replaced at a later date (eg before shipment), by the removal of the lid and replacement of seals remote from the box location.

This paper describes the design and testing philosophy adopted with particular reference to the challenges posed by the 50 tonne rating and providing a leak testable containment system.

CONTAINER SPECIFICATION

The NDA (Nirex) has developed a suite of Waste Package Specifications, which describe the dimensions, key features and performance requirements for each of the proposed standard waste packages. They include specific requirements for each package and formed the basis for the detailed container design specification for the UKAEA 2m Box. The NDA (Nirex) specification for the UKAEA 2m Box design is similar to that for the Nirex 4m Box (see Figures 1A and 1B) which was designed and a prototype manufactured and tested by Croft.

The principal requirements for the UKAEA 2m Box were that it be 2m long, top opening, have concrete shielding within a maximum gross package weight of initially 40t but this was raised to 50t as it was realised that the efficient use of the capacity of the box would result in a 50t gross weight. These key features had been identified in previous work carried out by NDA (Nirex) in which the general concept was developed and outlined in Waste Package Specification WPS/350 [ref 2].

For the specific requirement of decommissioning waste from the Dragon and SGHWR, it had been established by the UKAEA that a shield thickness between 0 to 300 mm would be required. The test programme has concentrated on a box with 100 mm concrete shield thickness.

On developing the general concept for the UKAEA 2m Box, it was determined that the container should be designed as a freight container meeting the specific requirements for freight containers in the IAEA Transport Regulations and to be subject to the appropriate tests for an Industrial Package Type 2 (IP-2) in accordance with the IAEA Transport Regulations [ref 1]. Design as a freight container was adopted as there are established standards (esp ISO1496/1 [ref 3]) for freight containers which cover design and testing of lifting, tie-down and stacking.

REGULATORY REQUIREMENTS

The UKAEA 2m Box is designed to meet the requirements for an Industrial Package Type 2 (IP-2) and also the specific requirements in the IAEA regulations for freight containers in accordance with the IAEA Transport Regulations [ref 1] which have been incorporated into UK legislation. In addition the design is consistent with guidance on the regulatory requirements for IP-2 freight containers issued by DETR [ref 5].

The specific requirements in the IAEA regulations for an IP-2 package are given in para 622 which require that the package meets:

- the requirements for Industrial Packages Type-1, and in addition, if it were subjected to the tests specified in paras 722 and 723, it would prevent:
- (a) loss or dispersal of the *radioactive contents*; and
 - (b) a more than 20% increase in the maximum *radiation level* at any external surface of the *package*.

The impact performance requirements adopted were those given in NDA (Nirex) document Specification for 2m Box Waste Package WPS/350 [ref2] is as follows.

The waste package should be designed such that, in the event of an impact accident:

- releases of radionuclides and other hazardous materials are low and predictable, exhibit progressive release behaviour with increasing impact severity and do not exhibit significant cliff-edge performance characteristics within the anticipated range of impact conditions;
- both of the barriers to radionuclide release from the waste package (i.e. the waste container and the wasteform) should play an effective role in minimising those releases.

The waste package shall be capable of being dropped, in any credible attitude, from a height of 0.3 metres onto a flat unyielding surface, whilst retaining its radioactive contents, without loss of shielding integrity that would result in more than a 20% increase in radiation level at any external surface of the package and remaining suitable for safe handling during all subsequent phases of the PGRC.

The waste package shall be capable of being dropped, in any credible attitude, from a height of 25 metres onto an unyielding surface, with a loss of contents as particles <100µm that should be no greater than 4A₂.

The following requirements were seen as the practical means of achieving the NDA (Nirex) requirements.

- The 2m Box shall be designed such that following the drop test described below it retains its contents, and still remains suitable for safe handling and disposal - that is, essentially unaffected by the drop test.
- The drop test shall consist of a 0.3m drop with the 2m Box horizontal and impacting onto an unyielding, horizontal, flat surface.

- An evaluation of the shielding shall be carried out to prove that there would be no more than 20% increase in radiation level at any external surface of the package.

The UKAEA 2m Box is a freight container by the definition given in IAEA TS-R-1.

The specific requirements in the IAEA regulations for freight containers are given in para 624 which require that the freight container meets the requirements:

- (a) The *radioactive contents* are restricted to solid materials;
- (b) They satisfy the requirements for *Type IP-1* specified in para. 621; and
- (c) They are designed to conform to the standards prescribed in the International Organization for Standardization document ISO 1496/1: “Series 1 Freight Containers — Specifications and Testing — Part 1: General Cargo Containers” excluding dimensions and ratings. They shall be designed such that if subjected to the tests prescribed in that document and to the accelerations occurring during routine conditions of transport they would prevent:
 - (i) loss or dispersal of the *radioactive contents*; and
 - (ii) loss of shielding integrity which would result in a more than 20% increase in the *radiation level* at any external surface of the *freight containers*.

The UKAEA 2m Box meets the design requirements of ISO 1496/1 [ref 3], although not the “dimensions and ratings” which are not required for IP-2 freight containers.

In addition to the design requirements of ISO 1496/1, the UKAEA 2m Box is also designed to withstand a repository operational stacking test, based on the load from a six high stack of 50t boxes. The operational stacking load test requirement, which was adopted in the design specification, is in excess of that required within ISO 1496/1.

DESIGN REQUIREMENTS

Design Constraints

The following requirements and principles were identified as appropriate for the UKAEA 2m Box to meet NDA (Nirex) transport and repository requirements.

- The complete shell of the box is fabricated from stainless steel. This is required as the package is expected to be loaded and stored for an extended period before shipment and the use of stainless steel is expected to ensure that the package will still meet the regulatory and operational requirements after storage.
- Butt welds are required for the body panels to provide good long term corrosion resistance.
- The design incorporates concrete shielding of variable thickness to meet user needs. The concrete is not required to meet any structural requirements other than not crack sufficiently to loose shielding during extended storage.
- The skeletal frame (corner posts, top and bottom rails) of the container is required

to be able to withstand all the test forces applied to the container without assistance from the wall panels, lid or the concrete shielding.

- The wall panels are required to withstand the side and end test forces (which simulate loads from the contents) without assistance from the concrete shield.
- The top lifting attachment points are required to withstand ISO 1496/1 tests, without exceeding the permissible stress defined according to the crane design code BS 2573 [ref 4].
- The base restraint attachment points are required not to exceed yield when normal conditions of transport accelerations are applied.
- All containment welds are required to be externally visible, to allow access for verification of containment by leakage testing.
- The lid seal system is required for low compression force, the ability to accommodate tolerances in manufacture and to be compatible with proven verification methods for containment.
- The base is required to provide a distribution of floor loading compatible with deep repository design concepts.
- The corner posts of the container are required to be able to withstand the repository operational stacking load case.
- Leaktight containment is required which is verifiable by leak testing at the stages of design and manufacture. It is also desirable for the containment to be verifiable by leak testing at the stages of loading and pre-shipment.

Customer Requirements

The following requirements specified by UKAEA Winfrith were also incorporated into the design of the container.

- Integral shielding is required. This is important as it means that the box can be loaded directly at the facility being decommissioned, rather than transporting the waste to a special packaging facility. It also means that the UKAEA 2m Box does not require long-term storage in a high-grade shielded facility; the box can be stored in any building with adequate ventilation and a controlled environment.
- Variable shielding capability with flexibility on thickness and material is required. This will allow waste packagers to optimise the packing of the box, ensuring maximum packaging efficiency whilst maintaining dose rates compatible with Transport Regulations.
- Top loading with maximum size of box aperture is required. This is particularly helpful for decommissioning type wastes as it minimises the need for size reduction, thereby removing the need for double handling. This will have the effect of reducing the radiation dose uptake and cost associated with a decommissioning project.
- Leaktight containment is required which is verifiable by leak testing at the stages of loading and pre-shipment. This is advantageous as the packager is assured as to the integrity of the package at the time of filling and can test the lid-seal at the time of transport.

CONTAINER DESIGN

Mechanical Design

The UKAEA 2m Box design is shown in Figures 2A and 2B. The UKAEA 2m Box shell is fabricated entirely from stainless steel. The box is flat sided with internal reinforcement by 'L' channel sections. The floor is constructed from inverted 'L' sections which run between the side rails. These floor supports are fitted into the side rails, against which a 6mm thick floor skin is attached which completely covers the supports plus end and side rails. Only the corner fittings protrude below the otherwise flat floor panel. In order to maintain minimum shielding thickness without reducing the container cavity size, 'L' channel sections are fitted with the open side facing into the container so that it fills with concrete when the shield is cast.

Although it is not a formal requirement, the UK Competent Authority (DETR) was consulted during the project to seek interpretation of certain aspects of the regulations and endorsement of the approach being taken. In particular, the containment standard and testing, and the tie-down requirements were discussed. This was particularly relevant in the light of the latest IAEA Transport Regulations TS-R-1, and the explanatory material TS-R-2 in which the containment testing is more fully explained and the acceleration values are more clearly defined.

Tie-down Features

The UKAEA 2m Box uses the special corner fittings designed for the Nirex (NDA) 65t UKAEA 4m Box: standard corner castings could not be used as they are not available for the load resulting from a gross package mass of 50t and the accelerations required by the IAEA Transport Regulations. The corner fittings are also fitted at the four bottom corners of the box for effecting tie-down.

The adopted accelerations and design criteria for the UKAEA 2m Box tie-down components were as shown in Table 1.

Table 1 Accelerations for tie-down

Design Stress	Accelerations (g)			Conditions of Transport
	Longitudinal	Lateral	Vertical	
Less than yield	±5	±2	±2	Normal
Permissible stress (BS 2573)	±2	±1	1 (upwards) 2 (downwards)	Routine
Fatigue requirements	±0.2	±0.25	±0.6	Routine

Lifting Features

The UKAEA 2m Box is provided with purpose designed corner fittings at the four top corners of the box.

The lifting twistlocks designed for the Nirex (NDA) 65t 4m Box were specified for the UKAEA 2m Box: these require re-test and re-examination at intervals of 2 years or after 1000 lifts. The design criteria for the lifting twistlocks are as follows.

- Twistlock for lifting frame capable of lifting 50t box
- General shape and features compatible with BS 5237 ‘British Standard for Lifting Twistlocks’ [ref 8]
- Designed in accordance with BS 2573 [ref 4] ‘Rules for the design of cranes’
- Eccentric loading and impact factor of 1.3 require SWL of 22.3t.
- Proof testing to 2 x SWL provides axial load of 44.6t

Lifting Frame

A special lifting frame was designed for lifting the UKAEA 2m Box. The design criteria for the lifting frame are as follows.

- Twistlock to be capable of lifting 50t box with 2 twistlocks
- Design to be electrically powered for remote operation
- Safety interlocks required to prevent inappropriate operation
- General shape and features compatible with BS 5237 ‘British Standard for Lifting Twistlocks’ [ref 8]
- Designed in accordance with BS 2573 [ref 4] ‘Rules for the design of cranes’
- Eccentric loading and impact factor of 1.3 require SWL of 22.3t.

Shielding

The concrete shielding design allows the shield to be of variable thickness between 0 and 300 mm. The prototype was provided with 100 mm of concrete shielding which was cast directly against the container walls and floor. The container walls have angle ties welded on the inside to provide a key for the concrete and stiffen the walls. In addition to the ties, a sheet of reinforcing mesh was included in each shield: this was positioned 40 mm below the surface of the concrete.

A step is cast at the top of the concrete side and end shields. The step provides a key for casting the concrete grout cap.

The concrete shielding, when cast onto the steel walls of the container, will flow in between the 'L' members and into the corner posts. The only voidage remaining in the container after packing is any within the wasteform and a small volume between the top shield and the stainless steel lid.

The density of the cap grout concrete is lower than the density of the side shielding concrete and therefore the cap has to be adjusted in thickness to give the same degree of shielding.

Containment System

The containment system consists of the following elements:

- Body and lid of the box
- Lid seal (double seal)
- HEPA filter and filter housing

The concrete shield is not designed (or required) to provide any containment function.

The filter is required to prevent a pressure differential developing between the inside and outside of the UKAEA 2m Box as even a small pressure differential would produce significant stressing of the container shell (because of the large area of the container panels).

The NDA (Nirex) Waste Package Specification for the UKAEA 2m Box, states:

Boxes which may be susceptible to significant over-pressurisation shall be vented.

If a vent is fitted it should be designed to retain significant particulate activity.

A number of different mechanisms exist which could give rise to pressurisation; these include:

- radiolysis
- corrosion
- thermal degradation
- variation in ambient conditions

Venting of the UKAEA 2m Box is through a stainless steel high efficiency particulate air (HEPA) filter which is incorporated into the box lid. The HEPA filter has a tested efficiency of 99.997% against the release of particulate material greater than 2 microns.

It is also a requirement that the waste package is limited to solid contents and

therefore any release of radioactivity is confined to free gaseous radionuclides associated with solid LSA and SCO wastes.

The qualitative containment requirement of 'no loss or dispersal' under normal conditions of transport for IP-2 freight containers, can be interpreted as being met if the quantitative 10^{-6} A₂/h containment criteria for Type B packages under the same (normal) conditions of transport can be met.

This ensures that the hazard from the UKAEA 2m Box would be no greater than for a Type B container. The containment system is designed to prevent all leakage of solid wastes. The maximum free gas contents can be determined by consideration of the quantitative 10^{-6} A₂/h containment criteria and the design leakage rate for the package.

MANUFACTURE

Manufacture of the stainless steel structural shell of the UKAEA 2m Box was completed using standard freight container manufacturing methods and techniques. The pre-formed sections were assembled butted up to the eight corner fittings and posts with the construction welds made using the MIG and TIG processes. The MIG and TIG processes are favoured for these containers as they allow large amounts of weld to be laid quickly with minimum distortion.

The concrete lining shielding was cast in place directly onto each face of the container and floor (with the container orientated to have each face horizontal for its cast).

TESTING

Following manufacture, the prototype UKAEA 2m Box was subjected to testing for compliance with both the requirements of ISO 1496/1 and in para 622 of the IAEA regulations for an IP-2 package.

Mechanical Testing to ISO 1496/1

The following test programme was carried out to demonstrate compliance with the requirements of ISO 1496/1.

- The design features would withstand mechanical loads in accordance with ISO 1496/1 tests (normal conditions of transport tests).
- The shielding effectiveness would not be reduced by more than 20% by normal conditions of transport test (IAEA Safety Series 6, Paragraph 523, b, ii).
- The container would withstand NDA (Nirex) operational conditions.
- The design would prevent loss or dispersal when subjected to normal conditions of transport tests (IAEA Safety Series 6, Paragraph 523, b, i).
- Corner fitting testing - both top and bottom corner fittings.

An approved freight container test facility was used to test the container, but because of the high gross weight it was necessary to up-rate the test house so that the required

loads could be applied. It was also necessary to produce a special testing frame to allow the non-standard length container to be accommodated and loaded within the facility. The test frame also included features for applying the restraint test loads.

Floor loadings, which can be as much as twice the container payload, have to be applied during some of the tests. These are normally applied by loading the container with concrete or steel weights. The prototype UKAEA 2m Box could not be loaded in this manner as the number of the weights required to achieve the load could not be accommodated within the test facility. Therefore, to achieve the required load, a set of hydraulic cylinders was mounted centrally over the box aperture and used to apply a supplementary load to the conventionally placed weights.

Normal practice is to apply the side and end wall loads either by laying the container on its side and filling it with weights or by using an air bag inside the container. Neither method was suitable for the UKAEA 2m Box because of the magnitude of the required test load. The method adopted was to construct a loading frame, fitted with hydraulic cylinders, which could apply a uniform load to the wall by use of a spreader plate acting against sand bags placed against the appropriate wall.

The freight container tests were carried out without any concrete shielding as this is the weakest condition. Thus the testing of the unshielded box provides evidence that a shielded box of any shield thickness would also meet the test requirements.

The container design was assessed, the manufacture monitored, and testing witnessed by Lloyd's Register under the Container Certification Scheme. All of the tests were passed, and the container was issued with a CSC certificate under the International Convention for Safe Containers scheme.

Mechanical Testing to TS-R-1 para 622

The following test programme was carried out to demonstrate compliance with the requirements of IAEA TS-R-1 para 622.

- Leak testing of the box body and lid seal
- Visual examination of containment welds before the drop test
- Loading with lead and sand to produce a total weight of ~50t.
- Drop test of 300 mm
- Leak testing of the box lid seal
- Visual examination of containment welds after the drop test
- Examination of the concrete for cracks after the drop test

Containment Testing

The ability of the UKAEA 2m Box to provide containment was demonstrated by conducting leakage tests using the soap bubble method for the body and pressure drop technique for the seal.

A combination of metrology checks and leakage tests was also used to verify that containment was maintained during and following mechanical tests to ISO 1496/1. All the leakage tests performed were passed.

Body test

The body of the UKAEA 2m Box is leak tested by the soap bubble method (method A 4.2 in ISO 12807 [ref 6]).

The method involves pressurising the cavity of the box with air to nominally 100 mbar above ambient, and coating the surface (especially all welds) with a soap film. A leak is indicated by formation of bubbles on the surface. The method is suited to large volume containers, with accessible containment welds that require verification.

The pass criteria for the body leakage test for the UKAEA 2m Box is that there be no bubbles detected during the test from any part of the surface of the container body.

Total leakage rate is considered to be $< 0.1 \text{ bar cm}^3/\text{s}$ SLR (see [ref 6] for definition) when no bubbles are observed - this was established by Janicki and Hows in tests using Helium [ref 7].

A gas leakage rate of $0.1 \text{ bar cm}^3/\text{s}$ is equivalent to a single capillary of about 0.04 mm, diameter and length of 2 mm (the box wall thickness is 6 mm). Because of the extremely small size of the leakage path, a gas leakage rate of $0.1 \text{ bar cm}^3/\text{s}$ is considered unlikely to permit powder leakage from the box because:

- i there is virtually no driving pressure for leakage,
- ii the radioactive material is not concentrated powder but powder mixed (diluted) with a spectrum of non-radioactive materials, and
- iii the formation of aerosols containing radioactive material is considered to be unlikely due to the absence of significant mechanisms for making any radioactive powders airborne, and because of the nature of the contents.

Seal test

The lid seal of the UKAEA 2m Box is leak tested by the pressure drop method (method A 3.1 in ISO 12807 [ref 6]).

The leakage tests carried out on the lid seal consisted of three pressure drop tests on each occasion. The leakage tests were performed with the racking loads to ISO 1496/1 with leakage tests being performed before the load was applied, with load applied, and after the load had been removed.

The leakage test method involves pressurising the interspace formed by the seal arrangement and measuring the rate at which the pressure drops. The sensitivity of the method is inversely proportional to the test volume, and is therefore particularly

suiting to small volumes allowing short test times. The interspace volume of the seal fitted to the 2m ILW is approximately 700 cm³.

The pass criteria for the lid seal leakage test for the UKAEA 2m Box is that the Gas Leakage Rate < 1 bar cm³/s SLR.

The total leakage rate is calculated from the pressure drop over a given period of time from a known initial pressure and for a known ambient temperature and pressure. The test provides a measurement of the aggregated leakage rate (i.e. total of all leaks not individual leaks). Because of this a relaxation of a factor of 10 compared to the body containment pass criteria was adopted.

Typically for the UKAEA 2m Box seal results demonstrated a leakage rate of < 5 x 10⁻¹ bar cm³/s with a leakage test period of 10 minutes.

Although a quantitative leakage test (in terms of activity release) is not required, a quantitative gas leakage test having a sensitivity such that even powder contents are unlikely to escape from the containment system, provides a convenient and objective way of determining whether a containment system is adequate at any of the design, fabrication or periodic verification stages.

USAGE OF THE UKAEA 2m Box

Currently the program to decommission the Dragon and SGHWR reactors at Winfrith has been put on hold by the NDA. However, the UKAEA 2m Box is being considered for use in various other applications.

ACKNOWLEDGEMENTS

This work was commissioned by the United Kingdom Atomic Energy Authority at Winfrith and was funded by the Nuclear Decommissioning Authority.

SUMMARY AND CONCLUSIONS

A UKAEA 2m Box, as defined in the NDA (Nirex) Waste Package Specification for ILW, has been designed, manufactured and successfully tested to meet the requirements for an IP-2 package design as a freight container and shown to meet the requirements of both ISO 1496/1 and IAEA TS-R-1 para 622.

The work has confirmed the acceptability of the testing methods (in accordance with ISO 1496/1) for a freight container with a gross mass of 50t.

The UKAEA 2m Box project has demonstrated that the ISO freight packaging and handling systems can be adapted and developed to fulfil the exacting requirements of

the nuclear industry for the packaging, transport and disposal of large items of decommissioning waste.

The UKAEA 2m Box is being considered by the industry as one of the options for packaging large items of decommissioning LLW and ILW waste that meets the requirements for LSA material and/or SCO. The large size and integral shielding provide several benefits including minimising the need for size reduction of the waste.

REFERENCES

- 1 International Atomic Energy Agency, Regulations for the Safe Transport of Radioactive Materials, 2005 Edition, Safety Standards Series No. TS-R-1
- 2 Nirex, Specification for 2m Box Waste Package WPS/350
- 3 ISO 1496/1: 1990, Series 1 Freight Containers - Specification and Testing - Part 1: General Cargo Containers for General Purposes
- 4 British Standards Institute, Rules for the Design of Cranes, BS 2573: Part 1: 1993
- 5 A DETR Guide to the Approval of Freight Containers as IP-2 and IP-3 Packages. DETR/RMTD/0002 (Freight Containers), July 1999
- 6 ISO 12807:1996, Safe transport of radioactive materials - Leakage testing on packages
- 7 ISO M C Janicki, R P Hows, Freight Containers as IP-2 Packagings. RAMTRANS Vol 5, Nos 2-4 (1994)
- 8 BS5237: 1985, British Standard Specification for Lifting Twistlocks

Figure 1A : NDA (Nirex) 4m Box - Dimensions

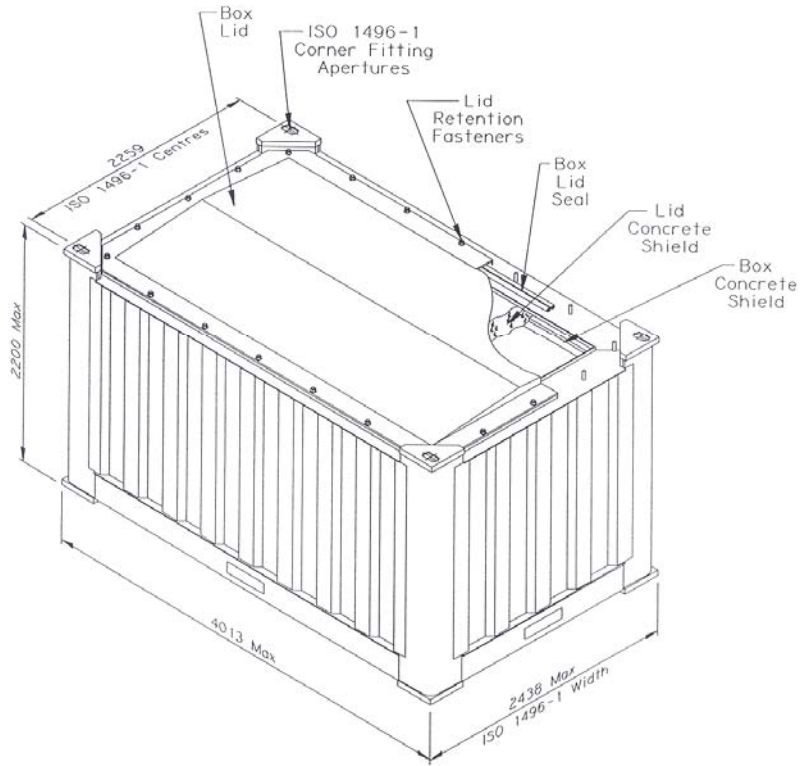

Figure 1B : NDA (Nirex) 4m Box – External view of finished box



Figure 2A : UKAEA 2m Box – Dimensions

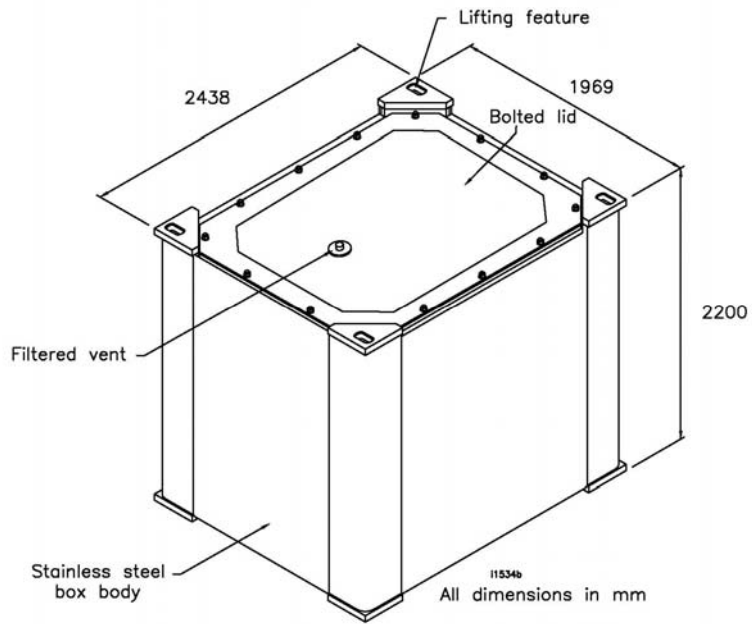

Figure 2B : UKAEA 2m Box – External view of finished box

