

Package Design No GB/2767P
Package Name: SAFPAK



Type

Designed as a Type A Package to the IAEA Regulations for the Safe Transport of Radioactive Material No TS-R-1 1996 Edition (Revised).

Certification

Licensed by Croft Associates Limited as a general purpose Type A Package and in particular for the carriage of medical radionuclides in solid or liquid form.

Approval Certificate No GB/2767P/A-96.

Other forms of radioactive material and/or primary packaging can be carried subject to a satisfactory safety review.

Description

Package Design No 2767P is designed as a reusable package and consists of an outer container Drum Design No 2767 which carries a resealable stainless steel inner Containment Can Design No 3933 within shock absorbing foam packing.

The container Drum Design No 2767 has a pressed stainless steel body and lid with a bayonet action closure.

The Containment Can Design N° 3933 is a resealable stainless steel containment can which carries the radioactive contents in primary containers. When contents are liquids in syringes, the absorbent material provided must be fitted inside the can. When the contents are bottles or vials, these may be packed in plastic bags/containers, or carried in lead pots when additional shielding is required.

Containment

The primary containment is provided by the Containment Can Design N° 3933. Secondary containment is provided by the absorber when syringes are carried, or by the bottle or vial. A wide range of primary packaging (including lead pots used with bottles or vials) can be used provided this packaging conforms to the specification referenced in the approval certificate.

Section through Package Design No 2767P

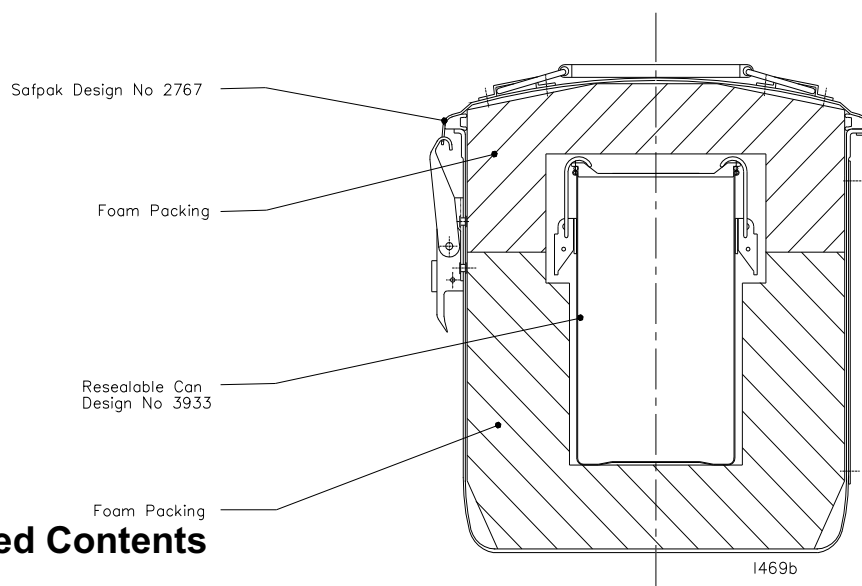

Approved Contents

Radioactive material in liquid, gas or solid form. A variety of sealed primary containers can be used with liquid contents (eg, vials). Absorbent material must be used with primary containers that are not sealed (eg syringes).

Liquid contents are limited to a maximum volume of 500 cm³ (0.5 litre) when packed in sealed primary containers and 160 cm³ when packed in non-sealed primary container (for which absorber is required).

Maximum contents weight of 3933 can is 2.5 kg.

The contents are also limited to A₁ for material in special form and A₂ for other material, with the additional requirement that the contents are limited to ensure that the external radiation levels of the package, as loaded and presented for transport, are within regulatory limits.

Physical Data

	Outer Container 2767	Foam Packing	Inner Container 3933	Contents of 3933
External Diameter	245 mm		125 mm max	
External Height	270 mm		178 mm max	
Internal Diameter	218 mm		96 mm	
Internal Height	255 mm		162 mm	
Tare Weight	2.9 kg	0.3 kg	0.7kg	2.5 kg max
Maximum weight of Package Design No 2767P (including contents) - 6.4 kg				

Further Information

Contact: Croft Associates Ltd, B2 North Culham Estate, Abingdon, Oxon, OX14 3GY, UK
 Tel: (01865) 407740 Fax: (01865) 407449 E-mail: sales@croftltd.com
 Web site: www.croftltd.com