

Package Design No 3979A

Package Name - Safkeg-LS



Package Type

Reusable Type B package for the shipment of solid and liquid radioactive materials.

Certification

The Safkeg-LS package is being certified by the USNRC as a B(U) Package - the package meets all the requirements of 10CFR71 and the IAEA Regulations for the Safe Transport of Radioactive Material, TS-R-1.

Description

The Safkeg-LS package is designed to be robust and simple to use. The package consists of a stainless steel outer keel which carries a stainless steel and lead shielding pot within cork packing.

The outer keel is fabricated in stainless steel with a flange type lid fastened by studs and nuts.

The shielding pot is a lead filled vessel with a fabricated stainless steel shell and cavity walls and a flange type lid fitted with double O-ring seals and fastened by screws.

Containment

The containment system consists of the shielding pot assembly: the containment being provided by the welded stainless cavity walls and the flange closure fitted with double O-ring seals. The pot lid is provided with a test point for leakage testing the containment system in accordance with ANSI N14.5.

Section through Package Design No 3979A

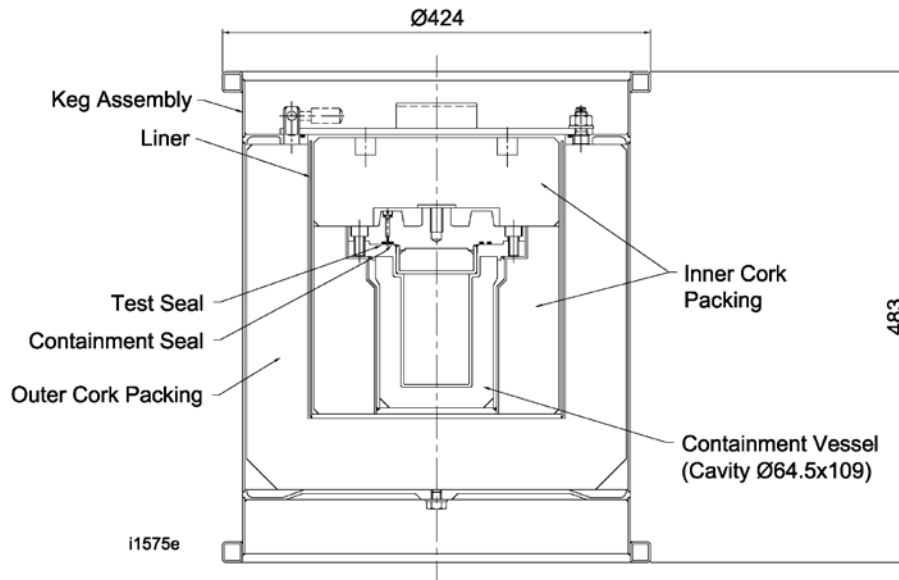

Approved Contents

The contents are solid or liquid radioactive materials carried in suitable primary containers to prevent contamination of the shielding pot.

The radioactive contents are limited by the amount of shielding incorporated, as noted below. The maximum contents heat output is 15 W.

The shielding pot may be fitted with additional shielding where required.

Modes of Transport

Road, rail, sea, air and inland waterway.

Physical Data

Safkeg-LS Package	Outer Keg		Inner Cork Packing		Inner Shielding Pot	
External Diameter	16.69"	424 mm			6.89"	175 mm
External Height	19.02"	483 mm			8.01"	203.5 mm
Internal Diameter	9.68"	246 mm			2.54"	64.5 mm
Internal Height	10.82"	275 mm			4.29"	109 mm
Tare Weight	73 lb	33.1 kg	6 lb	2.7 kg	49 lb	22.2 kg

Weight of empty package - 128 lb (58 kg).

Maximum weight of Safkeg-LS package (including contents) - 149 lb (68 kg).

The shielding built into the shielding pot is lead (20 mm min). Additional shielding is provided by a tungsten pot (25 mm max)

Further Information

UK - Croft Associates Ltd, F4 Culham Science Centre, Abingdon, Oxon, OX14 3DB, UK
 Tel: (01865) 407740 Fax: (01865) 407449 E-mail: info@croftltd.com
 Web site: www.croftltd.com

USA – Don Edling, Croft Inc., 1105 Old Cannons Lane, Louisville, KY 40209, USA
 Tel: 502 896 8597 Fax: 270 721 0025