

Package Design N° 2835A
Package Name: SAFKEG



Type

Designed as a B(U) Package in accordance with the requirements of the IAEA Regulations for the Safe Transport of Radioactive, No TS-R-1.

Certification

Certified by the UK Competent Authority: Certificate N° GB/2835A/B(U).

Description

The package consists of an outer keg Design N° 2835 which carries a resealable shielding pot, Design N° 2784, within an aluminium carrier and cork packing.

The outer keg Design N° 2835 has a fabricated stainless steel body with a large stainless steel lined cavity and a bolted stainless steel lid. The space provided between the fabricated body and the lined cavity is filled with a phenolic foam insulation.

The shielding pot, Design N° 2784, has a resealable stainless steel containment vessel and depleted uranium shielding encased in stainless steel. A small additional lead or tungsten shielding pot may also be carried within the cavity of the shielding pot, Design N° 2784.

Containment

The resealable shielding pot, Design N° 2784, provides the containment system for the package. The lid of the pot has double O-ring seals and has an interspace to facilitate leakage testing, to prove that the containment system has the prescribed levels of leak tightness.

Product containers such as screw top cans or sealed capsules are normally used to carry the contents and provide contamination control.

Section through Package Design N° 2835A

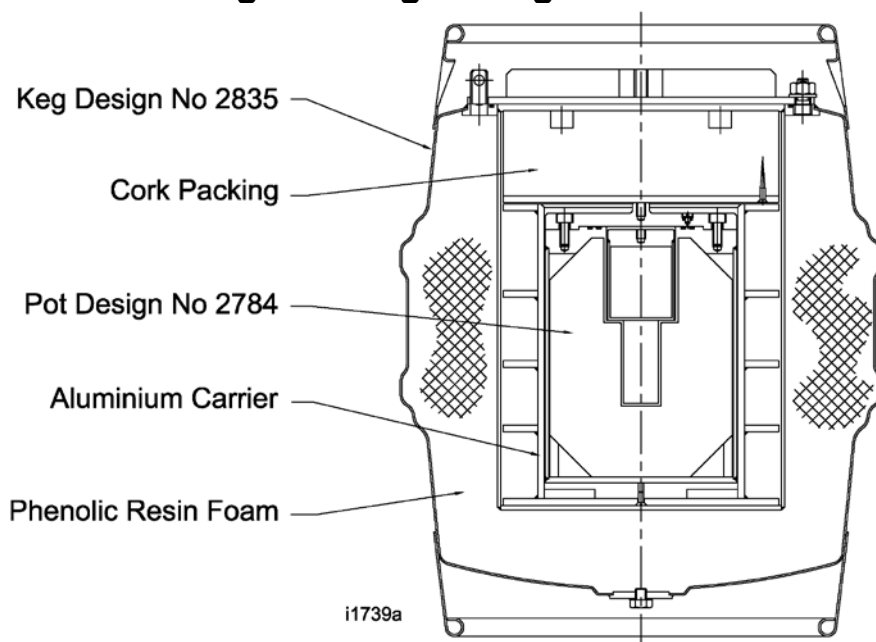

Approved Contents

370 TBq (10,000 Ci) Iridium-192 in the form of solid metal pellets. Samples of irradiated fuel pins containing up to 15g of fissile material (currently approved under the IAEA 1985 Regulations). Other contents could be approved.

Maximum heat emission of contents 57 watts.

External Dose Rates for 10kCi Ir-192

Inner shielding pot	Package Surface Dose Rate		TI (mrem/h)
	mSv/h	mrem/h	
Tungsten	0.4	40	1
None	1.1	110	2.7

Modes of Transport

Road, rail, sea, air and inland waterway (road, rail, sea and inland waterway – fissile variant).

Physical Data

	Outer keg 2835	Shielding pot 2784	Inner shielding pot
External Diameter	425 mm	168 mm	30 mm
External Height	540 mm	246 mm	72 mm
Internal Diameter	247 mm	31 mm	10 mm
Internal Height	355 mm	73 mm	52 mm
Shielding		63 mm DU	10 mm
Approximate Weight	48 kg (inc packing)	78 kg	0.85 kg (tungsten)
Maximum weight of contents			1.0 kg
Maximum weight of Package Design N° 2835A including contents			127.1 kg

Further Information

Contact: Croft Associates Ltd, F4 Culham Science Centre, Abingdon, Oxon, OX14 3DB, UK
 Tel: (01865) 407740 Fax: (01865) 407449 E-mail: info@croftltd.com
 Web site: www.croftltd.com