

**Package Design N° 2816H**  
**Package Name: SAFKEG**



## **Type**

Designed as a B(U)F Package to the IAEA Regulations for the Safe Transport of Radioactive Material, No TS-R-1.

## **Certification**

Certified by the UK Competent Authority: Certificate N° GB/2816H/B(U)F-96.

Validations for other countries can be obtained.

## **Description**

The package consists of an Outer Container Keg Design N° 2816 which carries a resealable Inner Container Design N° 2851 within insulating and shock absorbing cork packing.

The Outer Container Keg Design N° 2816 has a fabricated stainless steel body with a large stainless steel lined cavity and a bolted stainless steel lid. The space provided between the fabricated body and the lined cavity is filled with a phenolic foam insulation.

The Inner Container Design N° 2851 is a resealable stainless steel containment vessel.

## **Containment**

The resealable Inner Container Design N° 2851 provides the containment system for the package. The lid of the container has a double 'O' ring seal with an interspace between the 'O' ring seals; the interspace facilitates leak testing to ensure that the seals achieve the prescribed levels of leak tightness.

To reduce the possibility of contaminating the resealable Inner Container, primary containers such as screw top cans or sealed capsules are normally used to carry the contents.

## Section through Package Design No 2816H

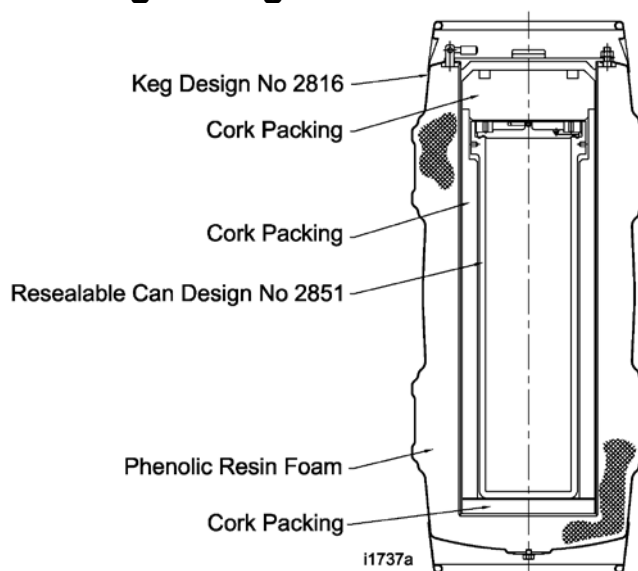

### Approved Contents

Solid Uranium and/or Plutonium metal, compounds and/or mixtures and Americium. Other contents could be approved.

Maximum activity will depend on the nature of the contents.

Maximum heat emission of contents not to exceed 80 watts and maximum contents weight 25 kg including packing within the inner container.

### Modes of Transport

Road, rail, air, sea, and inland waterway.

### Physical Data

	Outer Container 2816	Inner Container 2851
External Diameter	425 mm	210 mm
External Height	1000 mm	687 mm
Internal Diameter	247 mm	157 mm
Internal Height	821 mm	645 mm
Weight	67 kg	44 kg
Total weight of packaging Design N <sup>o</sup> 2816H - 122 kg (excluding contents)		

### Further Information

Contact: Croft Associates Ltd, Building F4 Culham Science Centre, Culham, Abingdon, Oxon, OX14 3DB, UK  
 Tel: 44 (0)1865 407740 Fax: 44 (0)1865 407449 E-mail: [info@croftltd.com](mailto:info@croftltd.com)  
 Web site: [www.croftltd.com](http://www.croftltd.com)