

Package Design N° 2802B
Package Name: SAFKEG



Type

Designed as both a B(U) and B(U)F Package in accordance with IAEA transport regulations, No TS-R-1.

Certification

Currently certified by the UK Competent Authority Certificate N° GB/2802B/B(U)F-96. Validations are obtainable for other countries, as required.

Description

The package has been designed for the transport of both radioactive solids and radioactive solutions.

The package consists of an outer container, Keg Design N° 2802, which carries a resealable inner containment container, Design N° 2853, which sits within a thermally insulating cork shock absorber.

The outer container keg Design N° 2802 has a fabricated stainless steel outer body with a large stainless steel lined cavity and a bolted stainless steel lid. The space provided between the fabricated body and the lined cavity is filled with a phenolic foam thermal insulation.

Containment

The resealable inner container Design N° 2853 provides the containment system for the package; a double containment system is provided by two separate lids.

Each lid has a double 'O' ring seal arrangement, with an interspace between the 'O' rings seals; the interspace facilitates leakage testing to ensure that the seals achieve the prescribed levels of leak tightness.

To reduce the possibility of contaminating the resealable Inner Container, primary containers such as screw top cans, sealed capsules or (for liquid contents), polythene bottles are used to carry the contents.

Section through Package Design N° 2802B

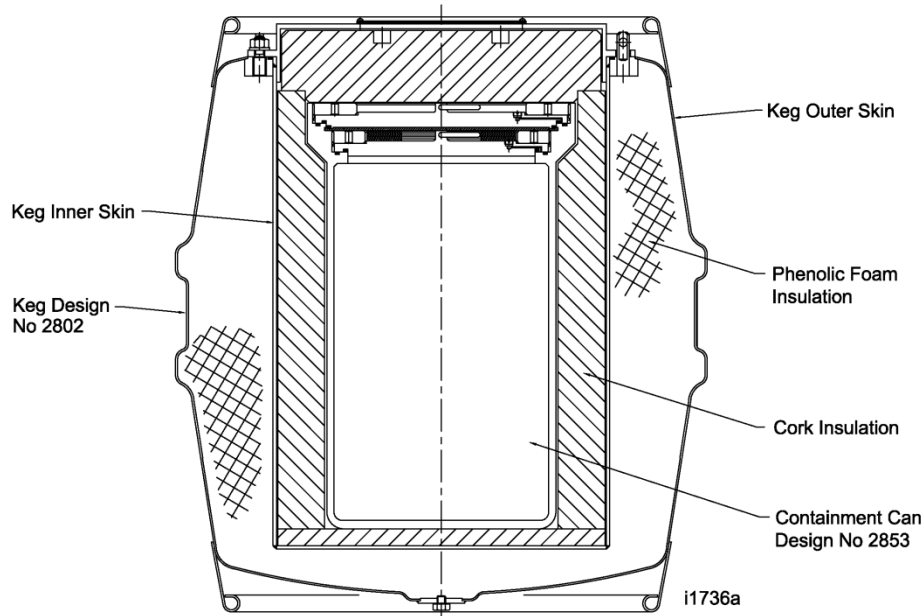

Contents

General purpose, but specifically approved to carry solids containing up to the equivalent of 135g of ^{235}U (100% enrichment), or up to 8 litres of neutral or acidic solution containing the equivalent of up to 135g of ^{235}U (100% enrichment) fissile material and/or other non-fissile radionuclides.

The package provides some shielding by itself, however, when additional shielding is required, a maximum 10 kg shielded pot can be fitted.

Maximum heat emission of contents is not to exceed either 1 watt for liquids or 15w for solids. Contents having a higher heat emission could be carried subject to a safety review.

Larger quantities of radioactive/fissile material could be approved if required subject to a safety review.

Modes of Transport

Road, rail, sea, air and inland waterway.

Physical Data

Package Design No 2802B	Outer Container 2802	Inner Container 2853
External Diameter	625 mm	317 mm
External Height	700 mm	502 mm
Internal Diameter	389 mm	254 mm
Internal Height	570 mm	430 mm
Weight	119 kg	61 kg
Maximum weight of contents		20 kg
Maximum weight of Package Design No 2802B including contents		200 kg

Further Information

Contact: Croft Associates Ltd, F4 Culham Science Centre, Abingdon, Oxon, OX14 3DB, UK
 Tel: (01865) 407740 Fax: (01865) 407449 E-mail: info@croftltd.com
 Web site: www.croftltd.com